



圆柄类刀具
一站式综合服务商

ROUND TOOLS ONE-STOP
GENERAL SERVICE PROVIDER



焊接PCD强力铣刀

专为高效加工而生



效率高



寿命长



单件成本低

用朴精密专注研发的焊接PCD强力铣刀是一款用于铝件和复材加工的高效高通用性铣刀，其强化的切削刃和刀体结构设计可以提供优异的排屑体验以及长寿命。刀体直径范围覆盖汽车和航空领域常用规格并提供非标解决方案。

设计特点



高强度
刀尖形式及避空设计



优化的PCD刃口宏观槽型



螺旋刃设计



双前角设计



金属去除率高



优化的容屑槽空间



大切深



切削轻快



量身定制

标准品系列

① 刀柄形状：直柄

柄部直径公差：h6
 切削直径公差DC：h10
 刀具直径：6.0-32.0
 最大坡走角度：5°

* 使用场合：铝件及复材加工

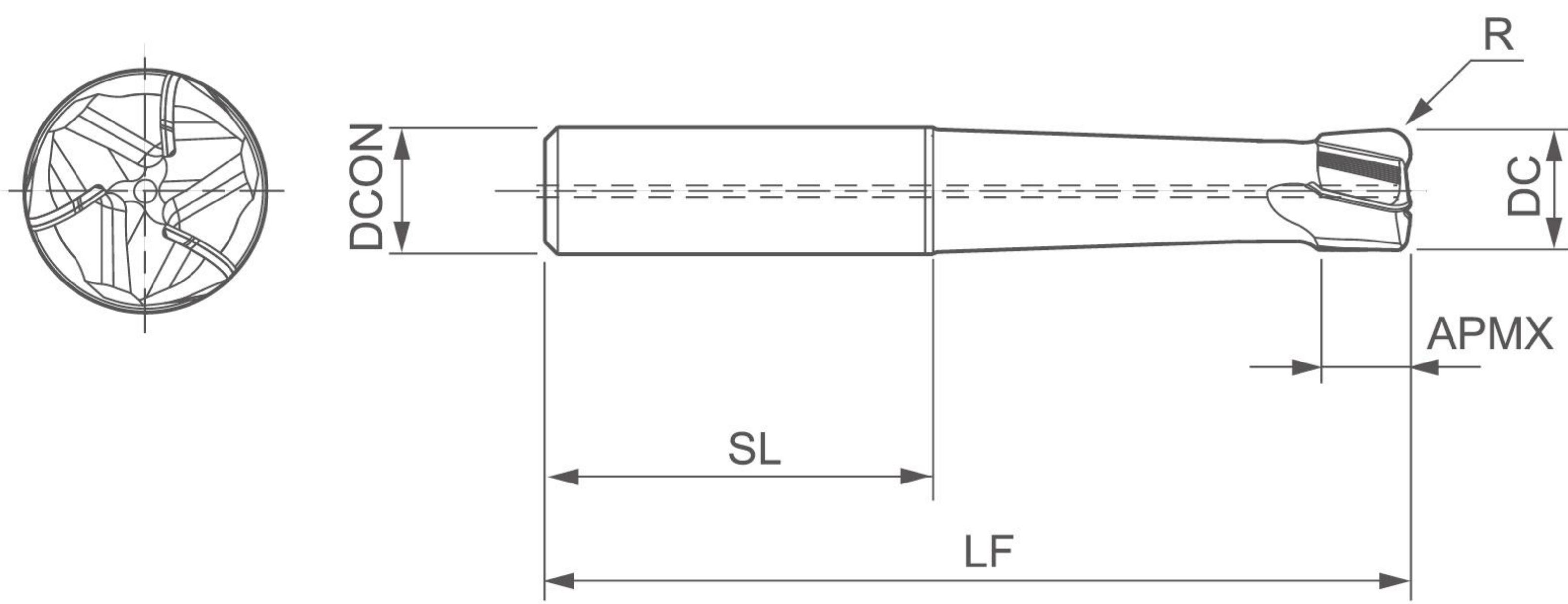

订货号	尺寸 (Dimension)							
	DC	APMX	LF	SL	轴向角度	刀尖R	刃数Z	刀柄形状
P290-06A6-3	6	6	60	36	9°	1	3	直柄
P290-08A8-3	8	7	70	36	9°	1	3	
P290-10A10-3	10	7.5	80	40	9°	2	3	
P290-12A12-3	12	8.5	90	45	9°	2	3	
P290-14A14-3	14	10	100	45	12°	3	3	
P290-15A16-3	15	10.6	100	48	12°	3	3	
P290-16A16-3	16	11.4	105	48	12°	3	3	
P290-18A20-3	18	12.8	115	48	12°	3	3	
P290-20A20-3	20	14.2	120	50	12°	3	3	
P290-25A25-3	25	17.8	145	56	12°	4	3	
P290-30A32-3	30	18.5	150	60	12°	4	3	
P290-32A32-3	32	20	150	60	12°	4	3	

② 刀柄形状：HSK

切削直径公差DC：h10
 刀具直径：32.0-50.0
 最大坡走角度：5°

* 使用场合：铝件及复材加工

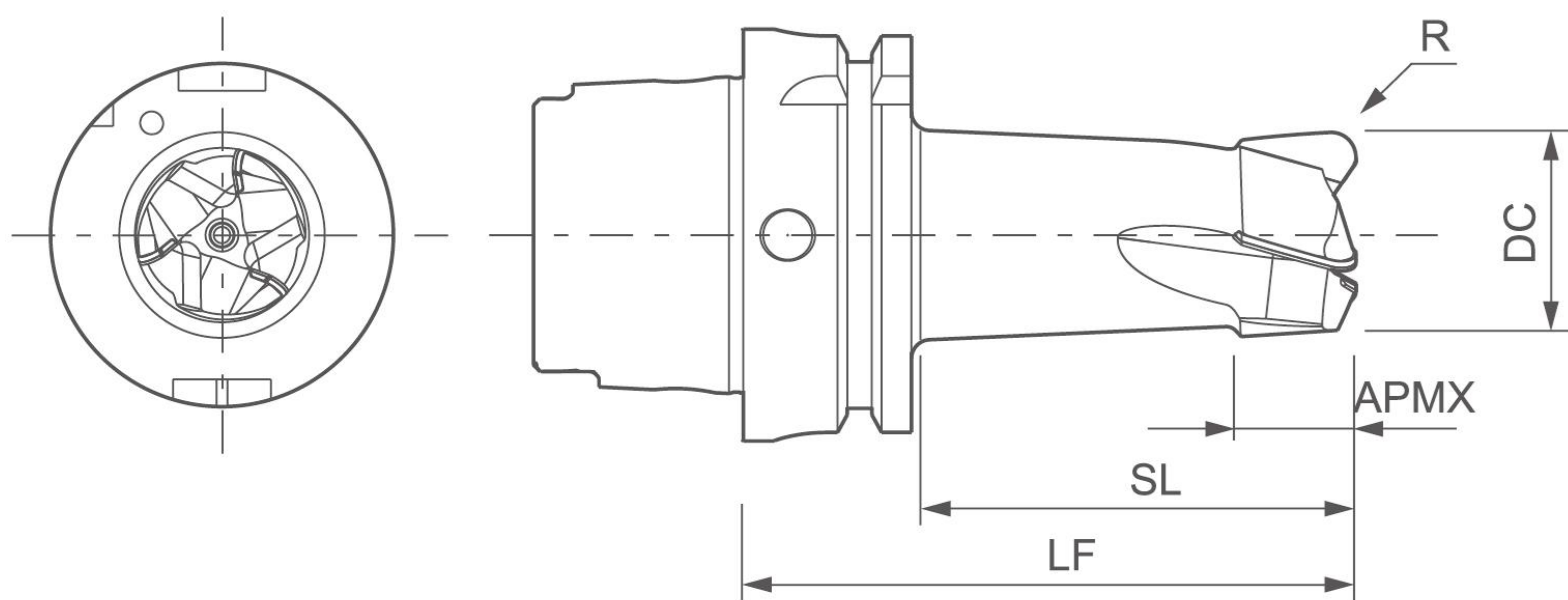

订货号	尺寸 (Dimension)							
	DC	APMX	LF	SL	轴向角度	刀尖R	刃数Z	刀柄形状
P290-32HKA63-3	32	18	85	56	12°	3	3	HSK-A63
P290-40HKA63-3	40	18	100	72	12°	4	4	
P290-50HKA63-3	50	20	110	81	12°	4	4	

非标定制 柄部形式可按客户要求定制

刀柄选项 HSK BT BBT Capto

* 非标品交货周期：4周

应用技巧

- 优选强力刀柄、液压刀柄等高刚性刀柄
- 设备转速高于10000rpm
- 刀具整体动平衡满足机床主轴要求
- 主轴和夹具刚性好
- 夹持后刀具的跳动小于5um

切削参数举例

① 普通铝件

刀柄形状	Dc	Z	N	fz	ap	ae
HSK-A63	32	3	18000rpm	0.26mm/z	10mm	22mm

② 机翼结构件 (材料：Aluminium 2124-T851)

刀具	N	vf	ap	ae
Ø25mm	16000rpm	5000 mm/min	10mm	22mm